

2014 SASHTO Conference

CHANGE

W **OASIS**

Our Advanced Solution with Integrated Systems

August 25, 2014

Topics

- *wv*OASIS Background
- Project Schedule
- CGI Advantage Implementation Methodology
- WVDOT Specific Benefits

wvOASIS Defined

- An enterprise resource planning or ERP system is a comprehensive suite of commercially-available integrated modules that provide end-to-end support for statewide administrative functions
- wvOASIS is the State of West Virginia's new ERP solution



wvOASIS Background

- Pre-implementation planning phase of the project initiated in May 2010
- Requirements defined for each functional area – more than 50 DOT staff participated in this effort
- RFP released in January 2011
- Evaluation of technical proposals and software demonstrations conducted in the Spring of 2011
- BAFO process conducted in summer 2011
- Contract signed with CGI on December 14, 2011



Governance

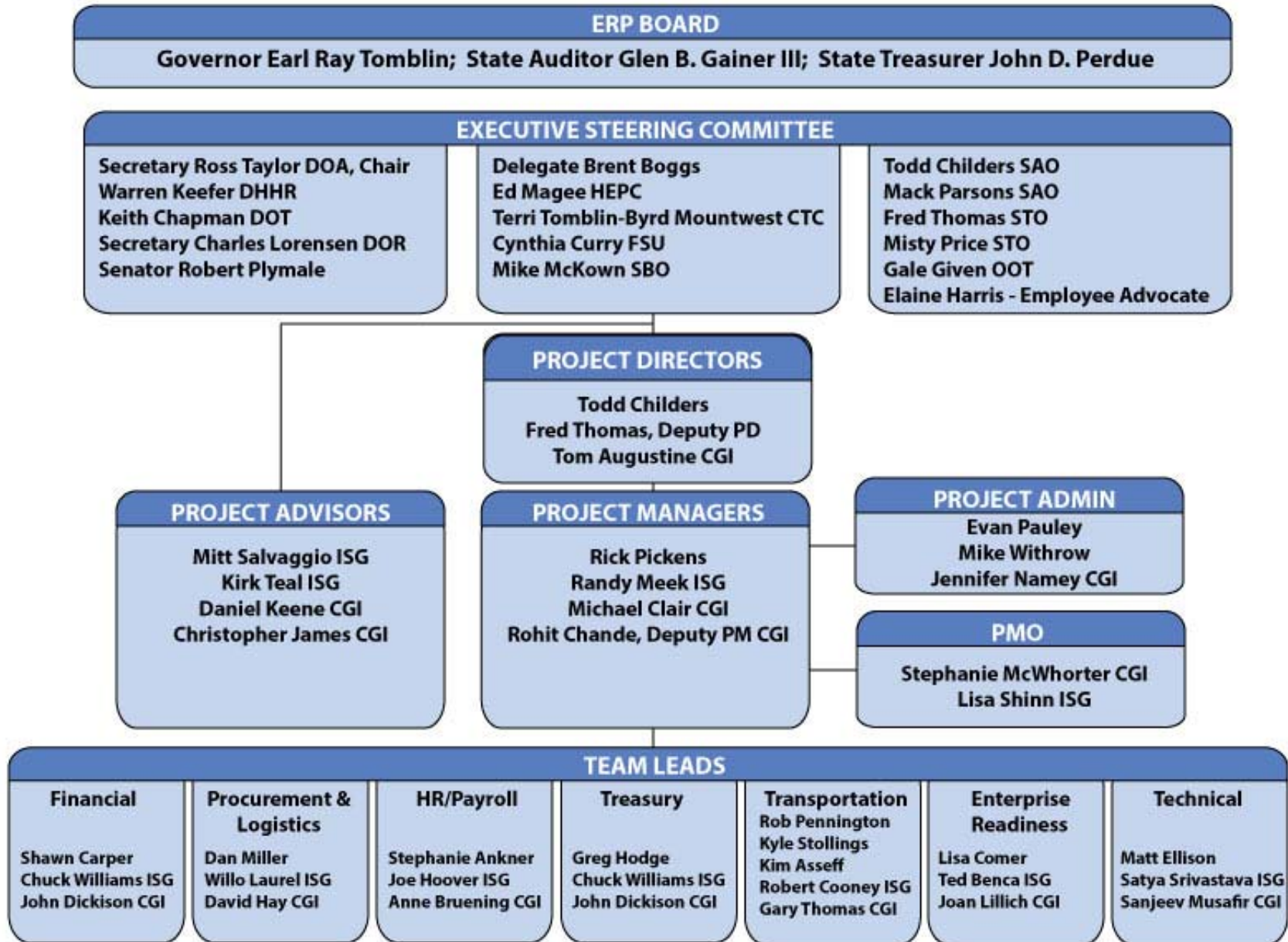

wvOASIS Scope

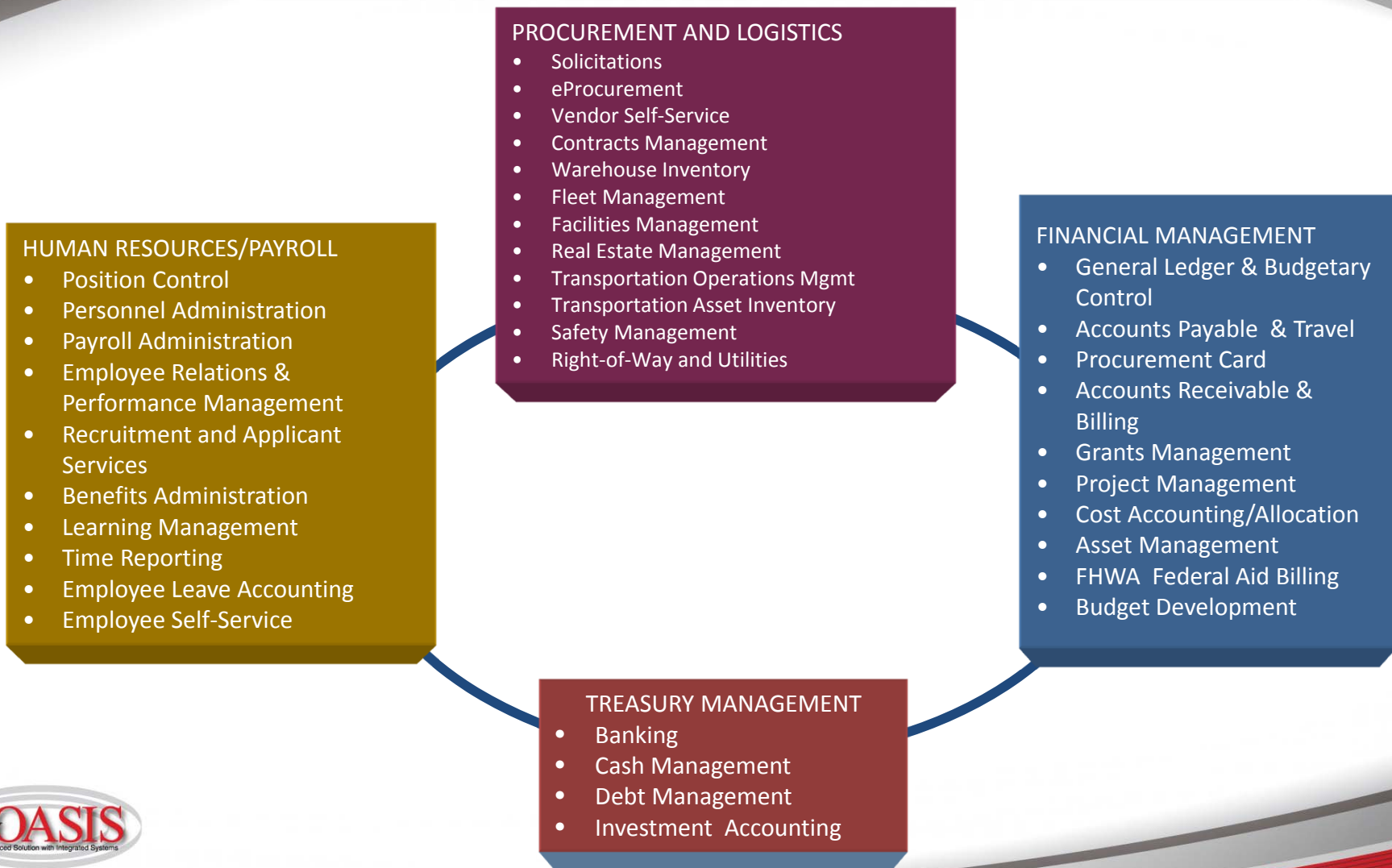

Time & Labor Interfaces

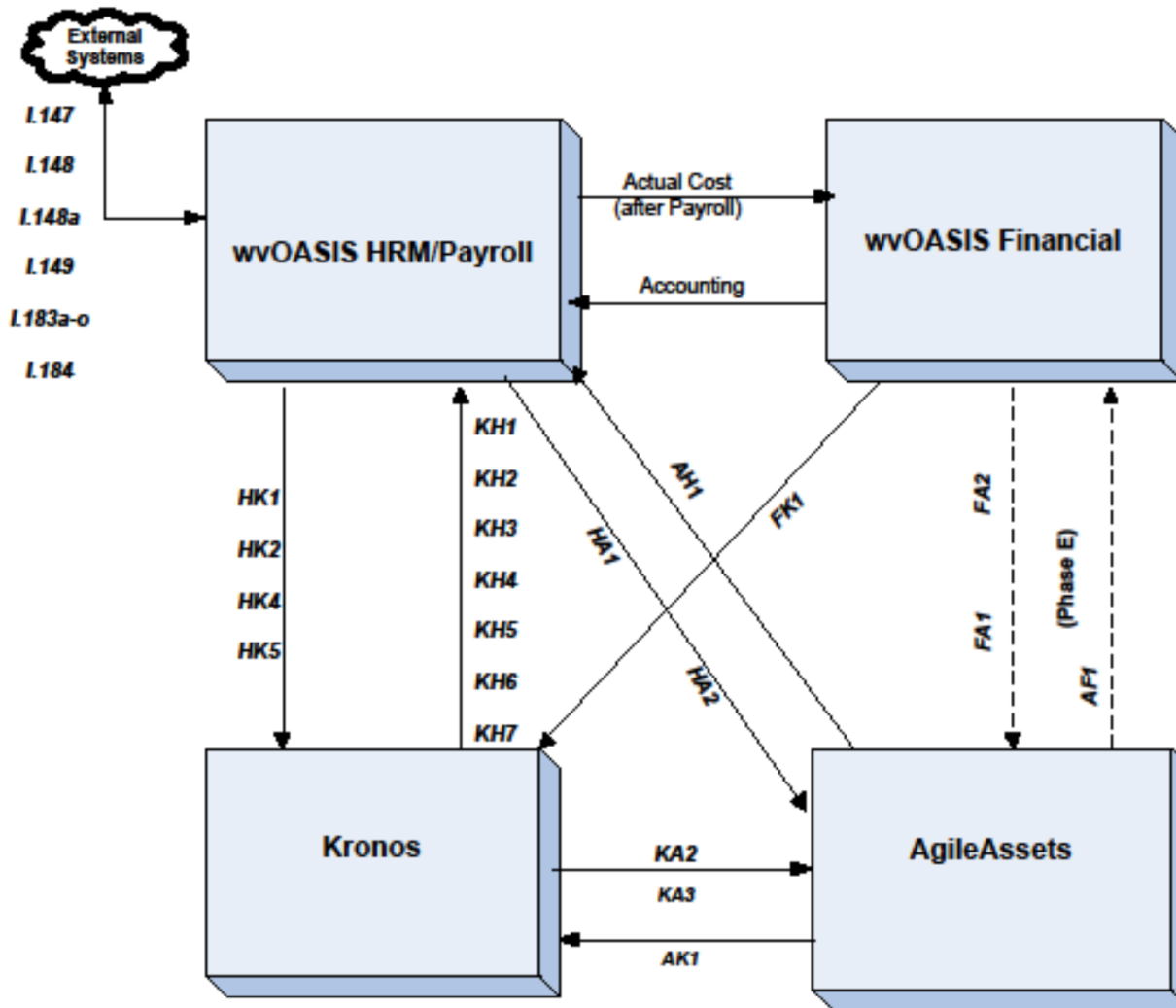

Note: The interfaces mentioned below are discussed in detail in the Phase D Interface Plan

HK1: Employee Demographics
HK2: Multiple Reference Table Data
HK4: Employee Labor Distribution
HK5: Certifications, Skills, and Licenses
KH1: Work Week Schedules
KH2: Leave Accrual/Leave Reset/Sick Leave Payback
KH4: Approved Timesheet interface for Payroll Processing
KH5: Time and Leave Payout at Termination

The interfaces mentioned below were added after the approval of the Phase D Interface Plan

KH6: Preliminary Payroll
KH7: Supplemental Payroll

Note: The interfaces mentioned below would be discussed in detail in the Phase E interface Plan

FA1: COA Info to Agile
FA2: Fixed Assets to Agile
AF1: Vehicle Usage to FIN
AF2: Work/Task Order Numbers
FA3: Actual Costs

HA1: Employee Demographics	AK1: Entered Timesheets	KA2: Approved Leave Requests
HA2: Multiple Reference Table Data	FK1: Fixed Assets Setup to Kronos	KA3: Equipment Usage
AH1: Taxable Vehicle Use (Take-home Vehicle)		

Note: The interfaces mentioned above are discussed in detail in the Phase 3 Addendum

WVDOT To-Be Systems Environment

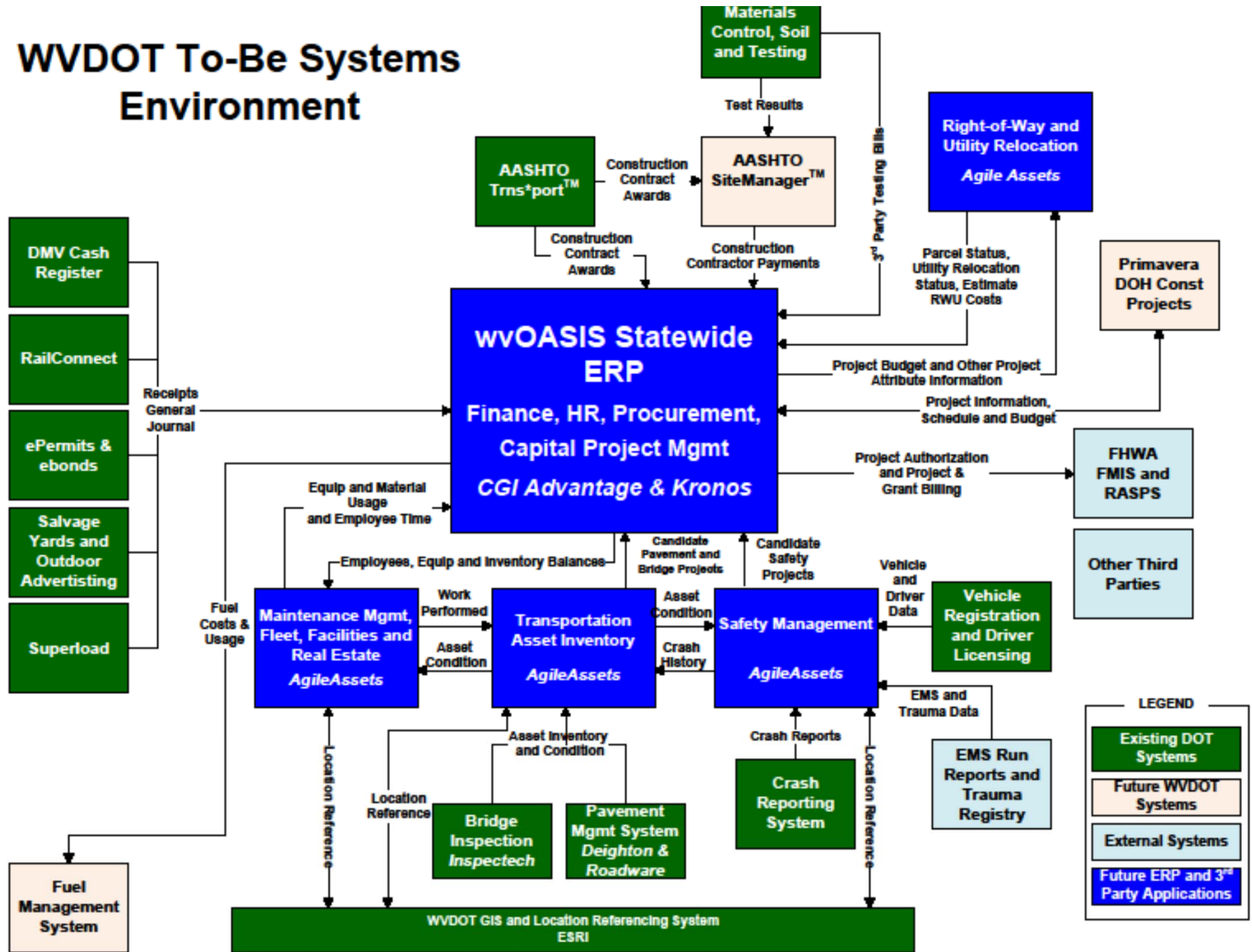

- BATCH
 NIGHT RUN
- REMIS TRANSACTION CODES**
 DR - Daily Work Report FA - Fixed Assets
 PH - Phone Directory PS - Payable Receipt
 EV - Evaluation RW - Work Requisition
 MV - Main Vendor Receipt RR - Receipt General (PCARD)
 IH - Inventory Transfer EM - Equipment Maintenance
 IT - Inventory Drop WM - Workcenter Management
 IS - Special Labor Usage

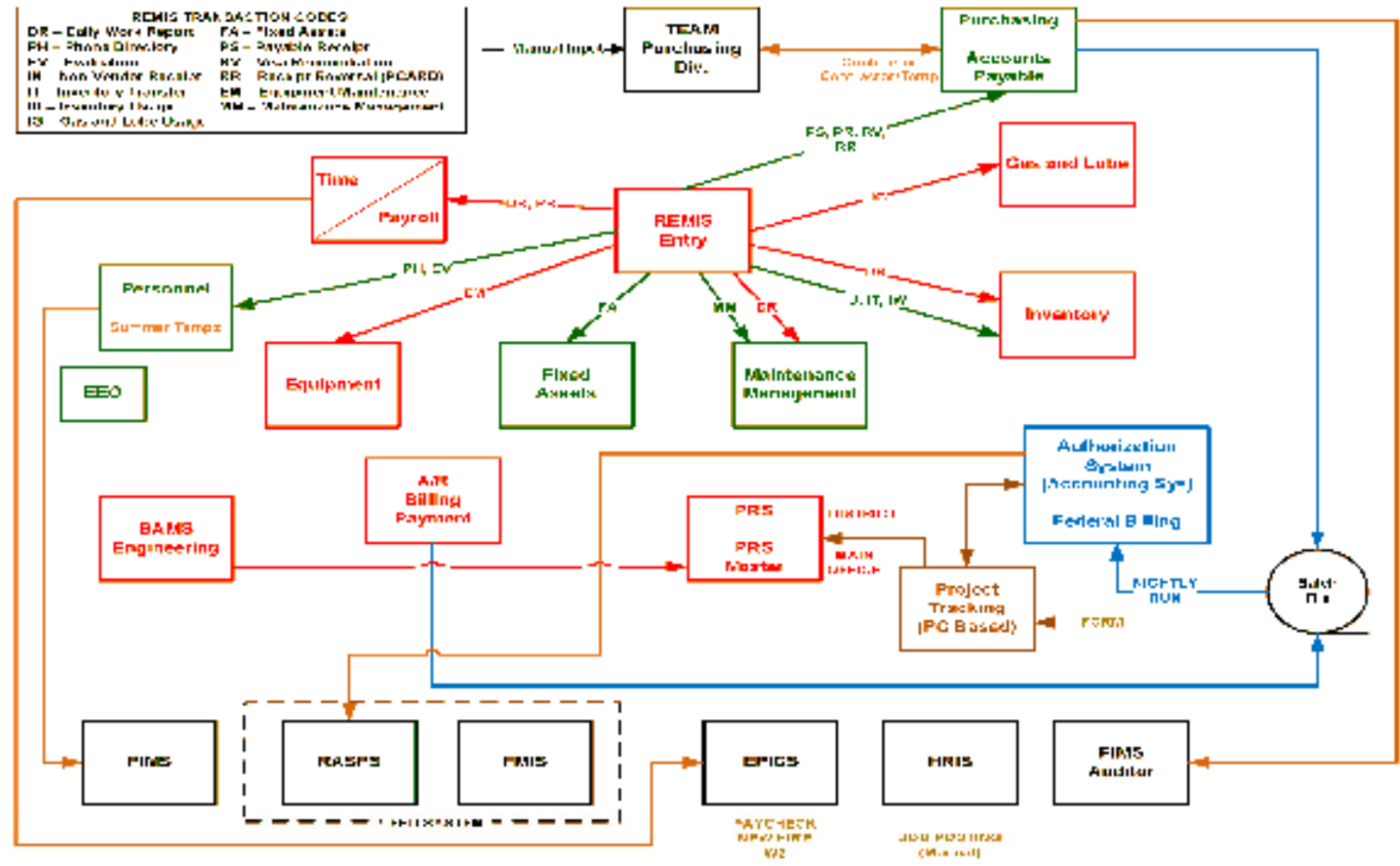

wvOASIS Solution

- CGI Advantage – Financials, Human Resources Procurement, and Performance Budgeting
- Kronos – Time and Leave
- AgileAssets – Transportation functionality, Fleet, Facilities and Real Estate



wvOASIS Key Benefits

- Consolidate numerous aging and redundant administrative systems across state government into a single, integrated ERP environment
- Facilitate the standardization of human resources/payroll policies and rules across state government
- Achieve more favorable pricing through enhanced procurement practices
 - Reduced Cost of Goods and Services
 - Process Efficiencies for the State
- Improve access to information
- Increase efficiency in the delivery of State services
 - Technical Improvements



Business Process Improvements

wvOASIS DOT Participants

Financial

- Vicky Casto
- Donna Cox
- Eric Crawford
- Susan Creager
- Parrish French (Parkways)
- Marty Gibson
- Jim Hash
- Mendy McClure

HR/Payroll

- Jeff Black
- Mike Bradley
- Maria Catalano
- JoAnn Twohig

Technical

- Bob Brabbin
- Jr Oliver
- Lynette Shaw



wvOASIS DOT Participants

Procurement

- Anthony Colombo
- Nancy Davidson
- Denise Gould
- Heather Huffman
- Clarence Hughart
- Travis Knighton
- Angie Moorman

Transportation

- Lynn Anderson
- Kim Asseff
- Toni Boyd
- David Brabham
- Cindy Butler
- Jennifer Cox
- Cindy Cramer
- David Cramer
- Sara Daniels



wvOASIS DOT Participants

Transportation

- Carolyn Gorrell
- Ron Hamilton (Parkways)
- Donna Hardy
- Ivan Kapp
- Bruce Kenney
- Brandi Krofcheck
- Marsha Mays
- Rob Pennington

Transportation

- Stephanie Price
- Travis Ray
- Carol Roush
- Todd Schoonover
- Kyle Stollings
- Eugene Tuckwiler
- Kyle Weatherholt
- Yueming Wu

Budget Development

PHASE A

Aug 2013

Safety
Right of Way
Utility
Transportation Asset Inventory

PHASE B

Jan 2014

General Ledger	Project Accounting	Financial Transparency
Budget Control	Cash Management	CAFR
Accounts Payable	Fixed Assets	Grants
Accounts Receivable	Purchasing	Investments
Pcard	Contracts	
Cost Accounting	Inventory	

PHASE C

July 2014

HR/Payroll	Employee Relations/Performance
Time & Leave	Billing
Position Control	Employee Self Service (ESS)
Class & Comp	
Benefits	
Learning	

PHASE D

Jan 2015

Transportation Ops & Assets
Safety
Federal Highway Administration Billing
Facilities & Real Estate
Travel
Federal Reciprocity

PHASE E Schedule Change...

Jan 2015

Legend:

Budget Development
Dept. of Transportation
Core Finance & Procurement
Human Resources & Payroll
Remaining Transportation Facilities & Real Estate

Phase E Extension

- Approved by ERP Board on April 14
- Scope of extension includes:
 - Go-live of Phase E extended to July 1, 2015
 - Agile Assets will go-live for remaining functionality in Version 7.X Signs and Signals now included in scope – targeting a go-live within 60 days of overall Phase E go-live
 - All DOT agencies except Parkways will now go-live on financials as of July 1, 2015

Implementation Methodology

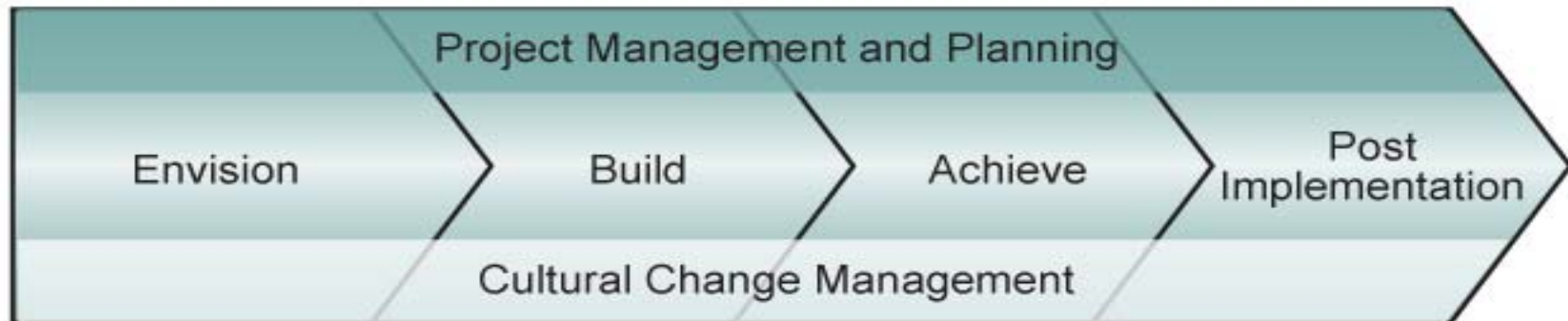

DOT Specific Benefits

- More flexible Federal-Aid billing engine to allow DOT to more easily implement business changes in future Highway bills
- Enhanced and more highly integrated transportation asset management solution to allow DOT to better control/manage total lifecycle cost of transportation assets
- Safety management solution based on industry best practices to support identification and prioritization of safety projects
- Enhanced tools to support the right-of-way acquisition and utility relocation processes reducing risk of project delay

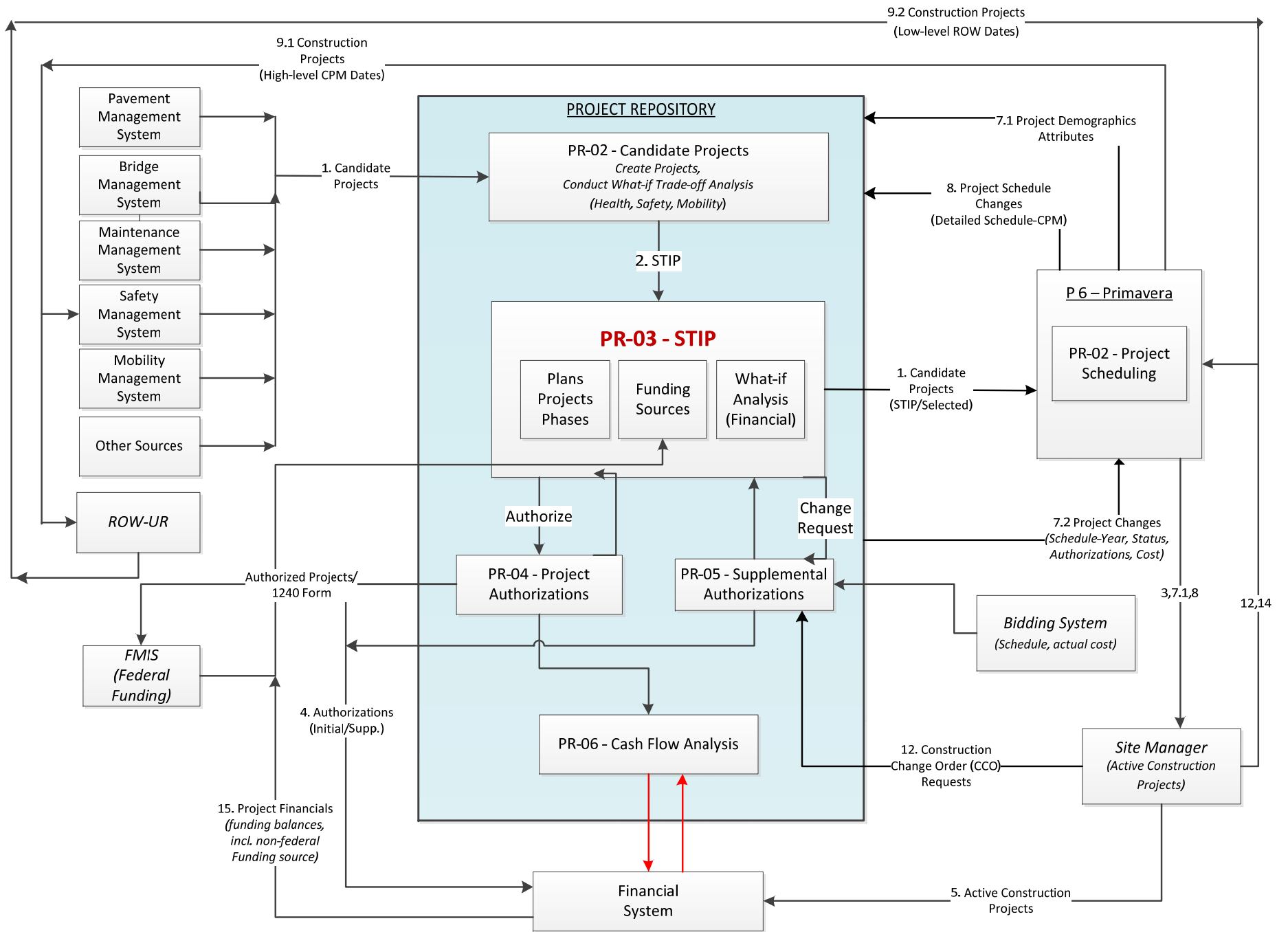

Example System - CPMS

What is CPMS?

- The Capital Program Management System will be the central repository for capital project data.
- Significant projects (e.g. roads, bridges, buildings) will be initiated and managed in CPMS.
- Deployed as a separate instance of Advantage Budgeting (v3.10)

Capital Program Mgt. System

- Funding assignment flexibility
- Integrated finance data tracking
- Web-based workflow
- Enhanced Reporting
- Forecasting Flexibility

Project Initiation Requests

- The project initiation request will be performed using budget forms.
- The standard workflow for budget forms will be utilized for the approval paths for each candidate project (some project phases will skip some stages of the workflow):
 1. Initiate Request [1010]
 2. Division/District Review [1020]
 3. Quality Review [1030]
 4. Project Review Committee [1040]
 5. Funding Assignment [1050]
 6. FMIS Approval [1060]
 7. Funding Authorization [1070]

Project 9901 Setup

CPMS Dimension Information

CGI Advantage Welcome, jgingrich Messages(0) [Home | Help | Preferences | Edit Password | Logout

Reference Data ▾ SBFS ▾ Projection/Allocation ▾ Security ▾ Utilities ▾ Budget Tasks ▾ Dashboards ▾ Integration ▾

Advantage Performance Budgeting > Reference Data > Dimensions > Projects > Project Maintenance > Edit Project

Edit Project | Project Schedule | Project Status | Performance Allocations | Road Inventory Log Data | DOT Program Attributes | Consolidations | Document Management

Save Copy

[Expand All](#) | [Collapse All](#)

Dimension Information ⓘ

* Code: * Element Type:

* Name: Active:

* Security Organization: ⓘ

Short Name:

* Scope of Project:

Financial Rollups Information

Category: ⓘ Type: ⓘ Group: ⓘ

Project Attributes

* Contact Person: Current Phase:

* Contact Phone:

* Contact Email:

Project 9901 Setup

CPMS Dimension Information

Project Information	
Existing Facility:	18'-22' HMA Rdwy 0-10' SHL
Termini:	0.13 MI N CO 10/4-Existing WV 10
Primary Route:	WV 10
Subroute:	
Begin Milepost:	011.62
Length:	0.80
Start Latitude:	
Start Longitude:	
Primary NBI Bridge/Tunnel Number:	
* Sign System:	3 - WV
* County:	23 - LOGAN
* Initiation Category:	X - SYSTEM EXPANSION
* Project Type:	3 - CON. PLANS ETC
* Supplemental Route Designation:	N/A
* MPO:	STATEWIDE
* District:	2
Direction:	NORTH/SOUTH
Project Asset:	0
Includes ROW?:	<input checked="" type="checkbox"/>
School Bus Route?:	<input type="checkbox"/>
Mail Route?:	<input type="checkbox"/>

Project 9901 Setup (continued)

CPMS Project Schedule



CGI Advantage Welcome, jgingrich Messages(0) [H]

Reference Data ▾ SBFS ▾ Projection/Allocation ▾ Security ▾ Utilities ▾ Budget Tasks ▾ Dashboards ▾ Integration ▾

Advantage Performance Budgeting > Reference Data > Dimensions > Projects > Project Maintenance > Edit Project: 2301 COA X > Project Schedule

Edit Project | **Project Schedule** | Project Status | Performance Allocations | Road Inventory Log Data | DOT Program Attributes | Consolidations | Document Management

Display Items

	*Original Estimated Start Date	*Original Estimated End Date	*Current Estimated Start Date	*Current Estimated End Date	Actual Start Date	Actual End Date	% Complete	Phase	Description
 <input type="checkbox"/>	<input type="text" value="01/31/2013"/>	<input type="text" value="01/31/2014"/>	<input type="text" value="01/31/2013"/>	<input type="text" value="01/31/2014"/>	<input type="text" value="02/15/2013"/>	<input type="text" value="12/31/2013"/>	<input type="text" value="100"/>	ROW - Right of Way ▾	
 <input type="checkbox"/>	<input type="text" value="02/25/2014"/>	<input type="text" value="03/17/2014"/>	<input type="text" value="01/20/2014"/>	<input type="text" value="02/10/2014"/>	<input type="text" value="01/20/2014"/>	<input type="text" value="02/10/2014"/>	<input type="text" value="100"/>	ENG - Engineering ▾	
 <input type="checkbox"/>	<input type="text" value="03/21/2014"/>	<input type="text" value="02/01/2015"/>	<input type="text" value="03/21/2014"/>	<input type="text" value="02/01/2015"/>	<input type="text" value="03/21/2014"/>	<input type="text" value=""/>	<input type="text" value="15"/>	CONSTR - Construction ▾	

Project 9901 Setup (continued)

CPMS Budget Request Details (ROW Phase)

CGI Advantage

Edit Budget Request | Phase Dollars | Program Information | Additional Notes | Document Management

[Expand All](#) | [Collapse All](#)

Budget Request Details 

* Request Code:	<input type="text" value="58"/>	* Name:	<input type="text" value="Rita Bridge CON"/>
Stage:	<input type="text" value="1070"/>	Ranking Type: 	<input type="text"/>
Description:	<input type="text" value="Budget request for construction phase of Rita Bridge-Midway Plaza project"/>	Ranking Type:	<input type="text"/>
Workflow Status:	<input type="text" value="Approved"/>	Current Rank:	<input type="text" value="0"/>
Budget Request Total:	<input type="text" value="7,500,001"/>		

Reason For Change

Project 9901 Setup (continued)

CPMS Budget Request Details (ROW Phase)

Budget Request Information

* Estimated Phase Cost: \$7,500,000

* Initiation Funding Comments: Dedicated funding is available

* Anticipated Phase Start Date: 03/21/2014

* Anticipated Phase End Date: 02/01/2015

* Initiation Funding Source: F-Federal Funding

Dimensions 

Project: 2301 *Rita Bridge* Phase: CONSTR *Construction* [Access Project](#)

Department: 0803 *DOH*

Justification Text

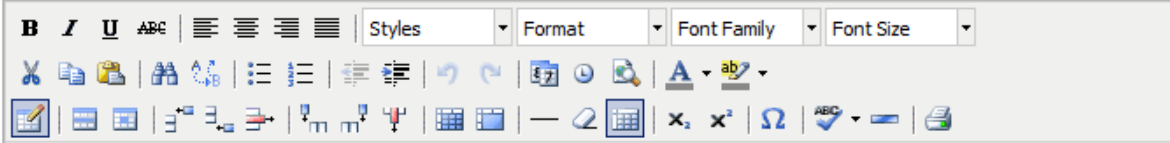
Justification Text: 
Critical component of Governor's statewide infrastructure improvement initiative.

Project 9901 Setup (continued)

CPMS Phase Dollars (ROW Phase)

CGI Advantage

Save Back

Edit Budget Request **Phase Dollars** Program Information Additional Notes Document Management

Budget Request Summary ⓘ

Layout Code: DOT PHASE INIT V2 Layout Type: Generic Request Code: 58 Request Name: Rita Bridge CON Stage: 1070
 Department: 0803 Project: 2301 [Access Project](#)
 Phase: CONSTR

Refresh Zero Out Display Sub Total: Select Model:

New Item Copy Item Delete Item Export Import Audit Trail View Graph Sgrt... View as CSV

Summary

<input type="checkbox"/>	Line	Fund	Appropriation Unit	Allocation	Federal Appropriation No.	FMIS Improvement Type	Funding Profile	Percent	Funding Priority	Current Year	Year 2	Year 3	Year 4	Year 5	Year 6	6-Year Total	
<input type="checkbox"/>	1	9017	00278	A10099	L003	48	C022	0.8	10	1,500,000	4,500,000					12,000,000	
<input type="checkbox"/>	2	9017	00278	A10099	STAT	48	C022	0.2	10	375,000	1,125,000					3,000,000	
<input type="checkbox"/>	3	9017	00278	A10099	NONP	48	C022		10							0	
Totals:										1	1,875,000	5,625,000	0	0	0	0	15,000,000

Budget Request History

Budget Request History

Back Display 20 Items Sort...

Items 1-12 of 12

<input type="checkbox"/>	Full Name	Workflow Action	Workflow State	Date & Time^	Comments
<input type="checkbox"/>	Initiator User	Submit	Submitted	10/28/2013 09:34:24	Ready to approve
<input type="checkbox"/>	Department User	Approve	Approved	10/28/2013 09:35:37	OK to proceed
<input type="checkbox"/>	Department User	Submit	Submitted	10/29/2013 00:56:50	
<input type="checkbox"/>	Quality User	Approve	Approved	10/29/2013 00:59:51	Looks good
<input type="checkbox"/>	Quality User	Submit	Submitted	10/29/2013 01:27:44	
<input type="checkbox"/>	Eva Melancon	Approve	Approved	10/29/2013 01:29:45	
<input type="checkbox"/>	Eva Melancon	Submit	Submitted	10/29/2013 01:40:23	PRC approved at 10/31/13 meeting
<input type="checkbox"/>	Joe Weiskircher	Approve	Approved	10/29/2013 01:44:33	
<input type="checkbox"/>	Joe Weiskircher	Assign	Assigned To Work On	10/29/2013 01:49:28	
<input type="checkbox"/>	Phil Casto	Assign	Assigned To Work On	10/29/2013 01:58:06	Completed, now leave me alone.
<input type="checkbox"/>	Joe Weiskircher	Submit	Submitted	10/29/2013 03:42:00	
<input type="checkbox"/>	Joe Weiskircher	Approve	Approved	10/29/2013 03:43:31	Ready for FMIS approval.
<input type="checkbox"/>	Joe Weiskircher	Submit	Submitted	10/29/2013 03:53:01	
<input type="checkbox"/>	Rob Pennington	Approve	Approved	10/30/2013 01:46:41	

- 
- Capital Program Management System
 - Placeholder slide

- 
- Capital Program Management System
 - Placeholder slide

Key AgileAssets Suite Features

Inventory

- What do you have?
- Where is it?
- What condition is it in?
- How much is it being used?
- Is it under warranty?
- When was it acquired or disposed of?
- Copy of plans, photos, documents, etc.

Budgeting – from costs per day/month/year to needs to forecasting

Condition Collection and Appraisal

Performance Management

Reporting – ease of data presentation to tell your story

Tables
Graphs
GIS



Transportation Asset Inventory TAI

- Flexible/extensible asset data repository to support managing all types of assets on the transportation network including:
 - HIGHWAYS – Planning, Equipment, Maintenance, Traffic Engineering, Information Services and Engineering Divisions
 - OTHER AGENCIES: Aeronautics, Port Authority, State Rail, Public Transit and DNR

Transportation Asset Inventory

TAI Matrix contains over 490 individual items in 47 different asset classes. Below is an overview of the current status.

180 - By Interface

52 - By Data Migration to be maintained in Agile

62 - Build Data Definitions to be maintained in Agile

19 - Implementation Deferred

17 - Duplicates

99 - System Functionality

62 - Will Not Implement



Current Phase B - TAI Summary by Responsible Division

Maintenance

Pavement	12
Condition Assessments	16
Drainage	6
Inventory Maintenance	14
Maintenance Feature	5
Roadside Features	1
Structures	7
LOS Rating Scales	5
All Assets	2
Customer Input	10
	78

Traffic Eng.

Pavement Markings	8
Traffic barriers	5
Signs	6
Crash History	33
	52

Program Planning

Point Assets	20
Code Tables	8
Linear Assets	22
Route Network	33
	83

Current Phase E - TAI

Summary by Responsible Agency/Division

Aeronautics Commission	26
Dept of Commerce DNR	6
Parkways	1
Port Authority	5
Public Transit	8
State Rail Authority	9

TRAFFIC ENGINEERING

ITS & Communication	9
Lighting	6
Outdoor Advertising	9
Roadway Features	1
Salvage Yards	6
Traffic Control	7

MAINTENANCE

Access Permits	9
Condition Assess	7
Data Integration	3
Drainage	6
Inventory Maint	4
Maint History	2
Roadside Facilities	7
Roadside Features	9



Transportation Asset Inventory

- Flexible/extensible asset data repository to support managing all types of assets on the transportation network including:
 - Aeronautics
 - Highways
 - Ports
 - Rail
 - Public Transit



West Virginia
dmy
Keeping West Virginia on the move.

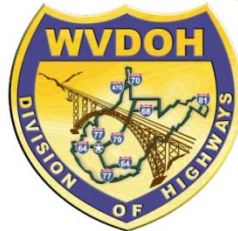

Transportation Asset Inventory

- Detailed asset inventory for select asset classes and types:
 - Location
 - Attributes specific to asset class and type
 - Construction history
 - Maintenance history
 - Crash history
 - Other events

Transportation Asset Inventory: Section Inventory

AgileAssets Management System [TAMS] Version 6.8 Build 14933

Road Maintenance Fleet Management Pavement Mgmt Facilities Maintenance ROW & Utilities Safety Resources System

Setup Inventory Issue Progress Analysis and Budgets Reports Utilities

Road Maintenance > Inventory > Inventory and PM > Sections > Section Inventory

Section Inventory

Section Inventory

1 Go 199 pages (5365 rows)

Section (name)	* Section Class Code	* Section status	Own PM	Organizational Unit	Centerline Miles	Total Lane Miles	Inspection Date	Record His
US012 47.05 - 49.66 (001910)	NHS	ROAD Active		0265 - District Two	2.608			No
US095 255.66 - 258.21 (001540)	NHS	ROAD Active		0250 - Wayne Cou	2.548			No
SH021 50.54 - 52.22 (002140)	SMA	ROAD Active		0836 - Pendleton C	1.685			No
US012 56.14 - 58.63 (001910)	NHS	ROAD Active		0265 - District Two	2.483			No
US012 49.83 - 51.57 (001910)	NHS	ROAD Active		0265 - District Two	1.742			No
SH022 62.58 - 68.15 (002470)	STC	ROAD Active		GARBAGE - Tyler C	5.566			No
SH021 47.7 - 48.92 (002140)	SMA	ROAD Active		0836 - Pendleton C	1.215			No
SH055 57.18 - 62.27 (007995)	NHS	ROAD Active		1070 - District Ten i	5.092			No
SH014 38.79 - 41.03 (001970)	STC	ROAD Active		0271 - I-64, Sector	2.231			No
US012 51.57 - 52.49 (001910)	NHS	ROAD Active		0265 - District Two	0.921			No
US030 204.41 - 204.69 (002040)	SMA	ROAD Active		0439 - Preston Cou	0.280			No
US030 204.33 - 204.41 (002040)	SMA	ROAD Active		0439 - Preston Cou	0.080			No
I015 184.7 - 189.62 (001330)	FAI 4-Lane	ROAD Active		GARBAGE - Tyler C	4.919			No
SH055 63.77 - 63.83 (001990)	NHS	ROAD Active		1070 - District Ten i	0.061			No
SH055 65.35 - 65.48 (001990)	NHS	ROAD Active		1070 - District Ten i	0.130			No
SH045 9.74 - 10.11 (002160)	SMA	ROAD Active		0399 - District Thre	0.366			No
US012 66.22 - 66.28 (001910)	NHS	ROAD Active		0265 - District Two	0.060			No
SH055 64.66 - 64.68 (001990)	NHS	ROAD Active		1070 - District Ten i	0.024			No
SH055 63.85 - 63.89 (001990)	NHS	ROAD Active		1070 - District Ten i	0.038			No
SH055 94.29 - 96.12 (001990)	NHS	ROAD Active		1070 - District Ten i	1.828			No
I084 236.4 - 236.96 (001010)	FAI 4-Lane	ROAD Active		0409 - Doddridge C	0.559			No
US095 252.41 - 252.8 (001540)	NHS	ROAD Active		0250 - Wayne Cou	0.384			No
SH055 82.06 - 84.39 (001990)	NHS	ROAD Active		1070 - District Ten i	2.329			No
SH055 71.5 - 74.14 (001990)	NHS	ROAD Active		1070 - District Ten i	2.640			No
SH055 62.27 - 63.27 (001990)	NHS	ROAD Active		1070 - District Ten i	0.499			No
US095 527.35 - 532.17 (001540)	NHS	ROAD Active		0103 - Boone Coun	4.820			No
SH200 55.97 - 57.72 (001610)	SMA	ROAD Active		0108 - Clay County	1.748			No

Transportation Asset Inventory (TAI)

- Target levels of service for select asset classes/types
- Condition assessments:
 - Condition history
 - Management scorecards
- Customer input
- Pre-defined reports
- Ad-hoc queries
- GIS integration
- Data integration with existing management systems (Pavement, Bridge, Crash Reporting)

Transportation Operations Management

Major functions / business processes:

- Annual Planning
- Scheduling Work (Work Orders)
- Recording Work Performed
- Resource Management (Labor, Equip, Materials, Dollars)
- Citizen's Request for Assistance
- Field Data Collection (Work Performed, Cond. Assessments, Trans. Asset Inventory, etc.)



Transportation Operations Management

TOM Objectives:

- To effectively plan and schedule Maintenance Activities
 - Annual \$300 million investment
 - Statewide mileage 38,800 miles
- Maximizing the efficient use of work time, material, and equipment.
- Improve the quality of maintenance work by adopting best methods and procedures



Transportation Asset Inventory

Total TAI Requirements = 500

Phase B (Part 1) = ~50%

- Core functionality to support Maintenance Quality Assurance (MQA) pilot in three districts:
 - Districts 3, 4, and 8
- Select Traffic Engineering asset types

Phase E (Part 2) = ~50%

- All other in-scope asset types to be deployed as part of Phase E
- Interface with Enterprise LRS (Esri Roads and Highways)



Right-of-Way Acquisition

Major system functions:

- Project set-up
- Parcel set-up
- Title abstracts
- Appraisal
- Negotiation and acquisition
- Relocation
- Management reports



Quick Links
 Parcel Class Codes
 (0) Parcel / Parcel Interest

Location Reference
 Statewide Routes

Color Schema
 Green

ROW-UR > Projects / Contracts > Projects

RWUR Projects

* State Project No.	S323-10-12 56 00	Financial Begin Date	
* ROW Federal Projec..	TCSP-0010/202/D	Financial End Date	
Org. Unit (District)	0562 - District Five Right-...	ROW Encumbrances (...)	\$2,867,000.00
* Project Name	RITA - DABNEY ROAD	Total Project Authoriz...	
Project Desc.	4 LANE FROM RITA - DABN	Project Fund Balance..	\$4,932,000.00
Eng. Resp. - Develop.		ROW Phase Orig. No	
Eng. Resp. - Consultant		ROW Phase Authoriz.	
Project Start Date	08/31/2010	ROW / Util Certified	
ROW Phase Start Dat.	08/31/2010	User Update	KNALLI
ROW Phase Start Dat.		Date Update	03/05/2013
Project End Date		Contracts	3
ROW Phase End Date..	10/20/2012		
ROW Phase End Date..			
ROW Phase Approved			
ROW Phase Authoriz.			

<<< 2 3 4 5 6 7 8 9 10 >>> Row 1 of 14 total rows

Construction Projects Location

Date Update	User Update	ROUTE	Direction	Lane	Start MP	End MP	Offset

<<<>> Rows 0-0 of 0 total rows

Project Distribution List Available Resources

Selected Project Distribution List

Project ID #	Employee	User ID	Licenses	Labor Class Code	Agency	Acquisition Activity	Comments	Att.	Date Update	User Update
12 1672460				Appraiser	0562 - District Five Right-of-Way	RWUR5 - Closing			12/29/2012	ABHISHEK
12 1672444				9433	0562 - District Five Right-of-Way	RWUR3 - Negotiation			12/19/2012	KNALLI
12 SANJ				Utility Coordinator	0562 - District Five Right-of-Way	RWUR2 - Appraisal			12/29/2012	ABHISHEK
12 DAVE HUFF				Appraiser	0562 - District Five Right-of-Way	RWUR4 - Condemnation			01/11/2013	ABHISHEK
12 DAVE BERRY				Negotiator	0562 - District Five Right-of-Way	RWUR1 - Title/Abstract Search or District Court-House Research			12/29/2012	ABHISHEK
12 1672401				9431	Agile-Assets	RWUR2 - Appraisal			12/19/2012	KNALLI
12 UDAAP				Relocation Specialist	0562 - District Five Right-of-Way	RWUR1 - Title/Abstract Search or District Court-House Research			12/29/2012	ABHISHEK
12 1672477				18113	CGI	RWUR4 - Condemnation			12/19/2012	KNALLI
12 1672486				9431	0562 - District Five Right-of-Way	RWUR2 - Appraisal			01/11/2013	ABHISHEK
12 1672496				18112	0562 - District Five Right-of-Way	RWUR5 - Closing			01/11/2013	ABHISHEK
12 Parson				Consultant / Contractor		RWUR2 - Appraisal			03/05/2013	IKAPP
12 Pletcher				Consultant / Contractor		RWUR2 - Appraisal			03/05/2013	IKAPP
12 Lucas				Consultant / Contractor		RWUR2 - Appraisal			03/05/2013	IKAPP
12 Kapp				Consultant / Contractor		RWUR1 - Title/Abstract Search or District Court-House Research			03/05/2013	IKAPP

<<< 1 2 >>> Rows 1-14 of 21 total rows





WOASIS
 District Five Right-of-Way System

Quick Links
[Parcel Class Codes](#)
[\(0\) Parcel / Parcel Interest](#)

Location Reference
 Statewide Routes

Color Schema
 Green

Projects

* State Project No.	S323-10-12.56.00	ROW Phase Start Dat.		Total Project Authoriz...	
* ROW Federal Projec...	TCSP-0010/2020	Project End Date		Project Fund Balance...	\$4,932,000.00
Org. Unit (District)	0562 - District Five Right...	ROW Phase End Date...	10/20/2012	ROW Phase Orig. No	
* Project Name	RITA - DABNEY ROAD	ROW Phase End Date...		ROW Phase Authoriz.	
Project Desc.	4 LANE FROM RITA - DA...	ROW Phase Approved		ROW / Util Certified	
Eng. Resp. - Develop.		ROW Phase Authoriz.		User Update	KNALLI
Eng. Resp. - Consultant		Financial Begin Date		Date Update	03/05/2013
Project Start Date	08/31/2010	Financial End Date		Contracts	3
ROW Phase Start Dat.	08/31/2010	ROW Encumbrances (...)			\$2,867,000.00

<<< 1 2 3 4 5 6 7 8 9 10 >> Row 3 of 14 total rows

Parcels

Project ID	* DOH Parcel #	* Parcel Name	Street	City	State	Zip Code	Latitude	Longitude	Address Locations	Update Geometry ?	Geometry	Address	Comments	Parcel Class Code	Tract	Att.	Pls #
	12 1683602 - Business	Test 2 Begins (Parcel Name TBD)	1844 Roundhill Terr	Charleston	WV	25314	-81.6247	38.3325	2		MULTIPOINT ((-81.6247 38.3325))	1844 Roundhill Terrace Cha...		Business			5
	12 Residential Towers	EST	1844 roundhill terr	Charleston	WV	25314	-81.6247	38.3325	3		MULTIPOINT ((-81.6247 38.3325))			Vacant Land			3
	12 1683609 - Business	TBD	1 John Marshall Dr	Huntington	WV	25755	-82.4302	38.4228	2		MULTIPOINT ((-82.4302 38.4228))	1 John Marshall Dr Hunting...		Business			1
	12 1683608 - Business	1683608 - Business	312 MacCorkle Ave	Charleston	WV	25301	-81.6394	38.3474	2		MULTIPOINT ((-81.6394 38.3474))	312 MacCorkle Avenue SE...		Business			0
	12 1683613 - Business	TBD	2700 Mountaineer E	Charleston	WV	25309	-81.7179	38.3187	2		MULTIPOINT ((-81.7179 38.3187))	2700 Mountaineer Boulevar...		Business			0
	12 1683614 - Business	1683614 - Business	1604 Washington S	Charleston	WV	25311	-81.6163	38.3404	2		MULTIPOINT ((-81.6163 38.3404))	1604 Washington Street Ea...		Business			0
	12 1683616 - Business	TBD	1 John Marshall Dr	Huntington	WV	25755	-82.4302	38.4228	2		MULTIPOINT ((-82.4302 38.4228))	1 John Marshall Dr Hunting...		Business			0
	12 1683617 - Business	TBD	1100 Fiedderjohn R	Charleston	WV	25314	-81.6784	38.3398	2		MULTIPOINT ((-81.6784 38.3398))	1100 Fiedderjohn Rd Char...		Business			0

<<< 1 2 3 4 5 6 7 8 9 10 >> Rows 1-8 of 80 total rows

Parcel Interests

DOH Parcel #	* Parcel Interest Name	Ownership (what ?)	* Parcel Interest Types	Comments	Displaces ?	Date Update	User Update
1683602 - Business	Abhishek	00 - All / Entire Parcel	2 - Tenant & Occupant		No	04/09/2013	KNALLI
1683602 - Business	Carolyn	00 - All / Entire Parcel	2 - Tenant & Occupant		No	03/07/2013	KNALLI
1683602 - Business	Abhishek - Land	02 - Private Structure	3 - Lease		No	03/07/2013	KNALLI
1683602 - Business	Carolyn - Land	01 - Land	1 - Owner & Occupant		No	03/07/2013	KNALLI
1683602 - Business	Abhishek & Wife - Land	01 - Land	1 - Owner & Occupant		No	03/07/2013	KNALLI

<<< >>> Rows 1-6 of 6 total rows



Utilities Relocation / Railroad Agreements

ROW & Utilities
Road Maintenance
Fleet Management
Pavement Mgmnt
Facilities Maintenance
Safety

Reports
Utility / RR Acquisition
Request
ROW Acquisition
Projects / Contracts
Inventory / Setup
Tools

ROW-UR > Utility / RR Acquisition > Utilities

Projects

<< 3 Go >> 6 pages (6 rows)

Project ID	4	ROW Phase Cost (Est.)	\$570,803,845.00	Project Fund Balance	
Comments		Overall Project Cost (Est.)	\$50,000,000.00	Project Name	I-
Att.		Project Cost History ?	<input type="checkbox"/>	ROW Phase End Date	1
User Update	ABHISHEK	Project Description	Expansion of existing 4 lane	ROW Phase Start Date	0
Date Update	05/30/2012	ROW Encumbrances		ROW Budget	
		Project End Date	05/10/2013	ROW Phase Approved ?	<input checked="" type="checkbox"/>
ROW Phase Cost (Actual)		Federal Project #	AI-02-ROW-001	Project Start Date	0

Utility Company

<< 1 Go >> 7 pages (32 rows)

Project ID	Utility / RR Index Element (#)	Utility / RR Name	Utility Company Name
4	1	Waterworks Corp	1 - WV American Water
4	2	Water Lines	1 - WV American Water
4	4	Gas Lines	5 - Pacific Gas
4	7	Power Lines	4 - Power and Light Inc

Utility Inventory

<< 1 Go >> 2 pages (7 rows)

Project ID	Utility / RR Index Element (#)	Utility ID	Utility Company Name	Utilities Class Code	Utilities Status
4	7	1686626 - Electric Poles	4 - Power and Light Inc	Electric Poles	1 - Active
4	7	1686626 - Electric Poles	4 - Power and Light Inc	Electric Poles	1 - Active
4	7	1686629 - Electric Poles	4 - Power and Light Inc	Electric Poles	1 - Active
4	7	1686630 - Electric Poles	4 - Power and Light Inc	Electric Poles	1 - Active
4	7	1686631 - Electric Cables	4 - Power and Light Inc	Electric Cables	3 - New
4	7	1686632 - Electric Cables	4 - Power and Light Inc	Electric Cables	3 - New

Right-of-Way Functionality in Phase E

- Functions to be performed in Advantage are deferred until Phase E:
 - Procurement of consultants, appraisers, etc.
 - Right-of Way related payment processing

ROW - Conversions and Interfaces

- Conversions:
 - Manual load of right-of-way data for active projects from paper files
- Interfaces:
 - WVDOT CADD through GIS to Advantage for parcel inventory data
 - Application integration between Agile RWUR and EMC ApplicationXTender
 - Integration between WVDOTs GIS and Agile RWUR

Utilities & Railroads Module

- Project Information
- Utility Companies & Railroads Involved
 - Agreement/Permit Information
 - Contact Information
 - Relocation Status
- Project Specific Documentation for each Company

Utilities & Railroads Module

AgileAssets Management System [TAMS] Version 6.9 Build 16447 - 0562 - District Five Right-of-Way / KNALLI / System Role

T. Ops Mgmt & Asset Inventory Fleet Management Facilities & Real-Estate **ROW & Utilities** Safety Resources System

Tools Setup Projects / Contracts Workflow Progress Payments Utility / RR Acquisition Reports

ROW-UR > Utility / RR Acquisition > Utility Co-Ordination

Projects

* State Project No.	WV-OASIS-01-001	Project Start Date	05/09/2012	ROW Phase Authorized	ROW Phase Authorizati
* ROW Federal Project N	AL-02-ROW-001	ROW Phase Start Date (08/22/2012	Financial Begin Date	ROW / Util Certified
Org. Unit (District)	0562 - District Five Right-of-W	ROW Phase Start Date (I		Financial End Date	User Update KNALLI
* Project Name	I-74 Corridor Expansion	Project End Date	05/10/2013	ROW Encumbrances (E	Date Update 03/12/2013
Project Desc.	Expansion of existing 4 lane h	ROW Phase End Date (A	12/21/2012	Total Project Authorize	Contracts
Eng. Resp. - Developme		ROW Phase End Date (E)		Project Fund Balance (E	\$1,000,000.00
Eng. Resp. - Consultant		ROW Phase Approved		ROW Phase Orig. No	

<<< 1 2 3 4 5 6 7 8 9 10 >>> Row 3 of 14 total rows

Utility / RR Index

Project ID	Utility / RR Index Element (#)	Utility / RR Name	Utility Company	Utility / RR Type	Utility / RR Description	Responsible Party	Utility / RR - Lead Contact	Utility / RR Acq. Status	Assigned Co-ordinator	Agreement/Perm
4	52	GAS 1	8 - AT&T	1 - Public Utility	6" GAS LINE	1 - Company	CAROL COSTELLO	4 - Notice to Proceed		3 - Partial
4	54	utility q	7 - Mountaineer Gas	1 - Public Utility	electric line	1 - Company	joe brown	4 - Notice to Proceed		1 - Agreement
4	56	Water Utility Name	2 - Appalachian Power Co	1 - Public Utility	Sample Description	1 - Company		4 - Notice to Proceed		1 - Agreement
4	74					1 - Company		4 - Notice to Proceed		2 - Permit

<<< 1 2 3 4 5 6 7 8 9 >>> Rows 1-4 of 33 total rows

Utility / RR Coordination Log

Utility / RR Index Element (#)	Log Entry #	Log Entry Name	Utility/RR Log Type	Log Entry Description	Log Entry Send Date	Comments	Att.	User Update	Date Update
52	32		2 - Memo	I met with Chad today to	04/03/2013			KNALLI	04/03/2013
52	33		1 - Letter					KNALLI	04/03/2013

<<< 1 >>> Rows 1-2 of 2 total rows



Utility & Railroads Module

- Personnel using this module
 - Central Office Utility Staff
 - District Utility Staff
 - Project Managers
 - Management

Utilities & Railroads Module

- New Payment System (2015)
 - Faster Payments
 - Easier Tracking
- Asset Inventory
 - Utility & Railroad Information associated with roads/mileposts
 - From relocation plans & permits

Safety Management

- Perform crash identification, analysis and countermeasure identification
- Manage highway safety program
- Prepare safety related information requests
- Perform resource allocation
- Support highway safety plan emphasis areas

Systematic Safety Management Process

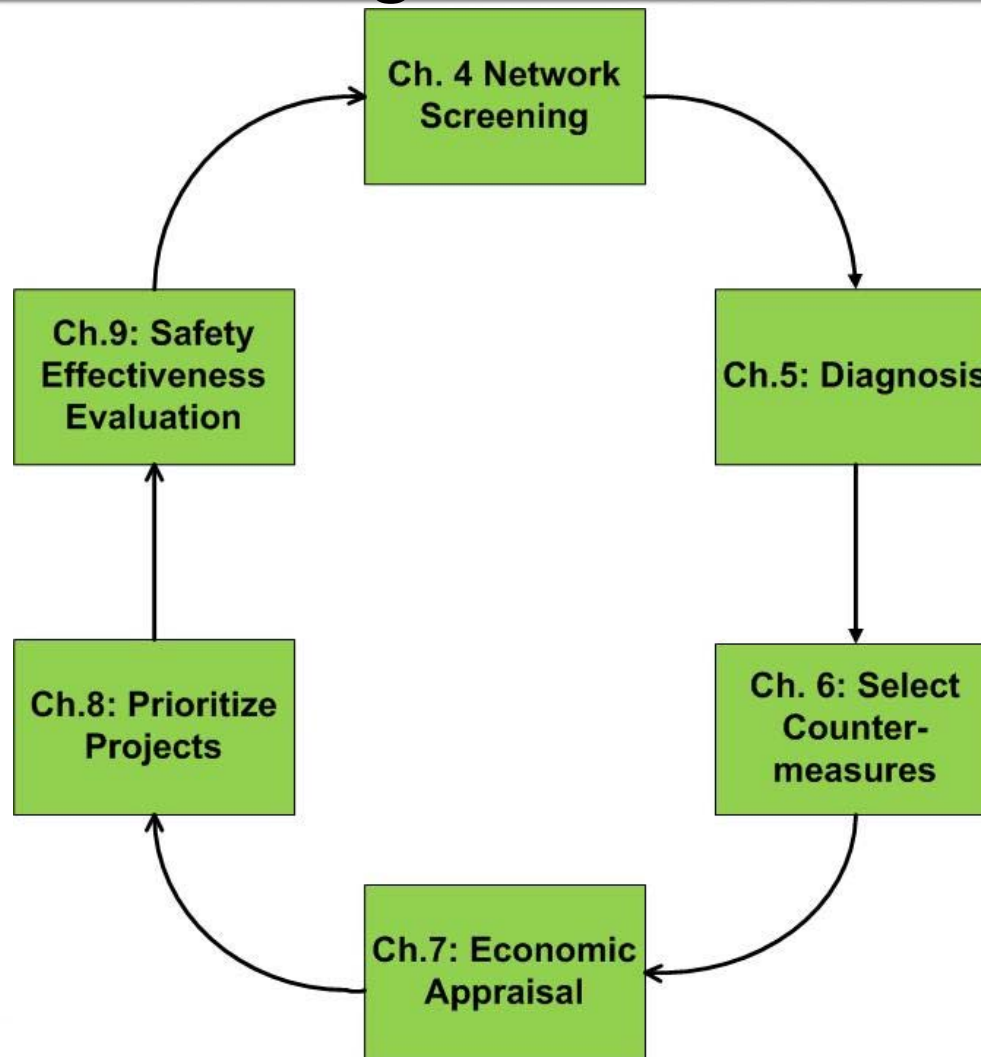

Safety Management Functions

- Network screening:
- Diagnostics:
- Project prioritization
- Safety grants management (Phase E)

Safety Management Functions

- Integrated safety database including:

Function	Planned Phase
Crash report	B
Driver history	E
Vehicle history	E
Citations	B
Convictions	E
Trauma registry	E
EMS run reports	E

Phase E interfaces subject to WVDOT receiving approval to utilize data for Safety Management

Safety Management: Screening and Diagnostic Tool

Safety > Diagnostics > Network Master

Scenarios

Scenario ID	Analysis Type	Comments	Date Update	User Update
108	Sliding Window	Shafiu test2	4/16/2012	SHAFIUL
110	Peak Search	Shafiu test 3	4/18/2012	SHAFIUL
111	Sliding Window	Shafiu test 4	4/21/2012	SHAFIUL
112	Peak Search	Demo	4/20/2012	SHAFIUL
113	Sliding Window	User group test	4/23/2012	SHAFIUL
114	Sliding Window	User Group2	4/24/2012	SHAFIUL
115	Sliding Window	Training Test	5/1/2012	SHAFIUL
120	Peak Search	TRAINING 1	5/7/2012	UDAY
121	Sliding Window	training	5/7/2012	UDAY

Rows 1-9 of 22 total rows

Network Master

Route	Direction	Lane	Offset	Start MP	End MP	Attach.	Comments	Date Update	No. of Fatal Crash	INS_FIXED_ANALYSIS_ID	INS_FIXED_ANALYSIS_P
I 469	Both (All)	All	0	14	16				0	108	
I 469	Both (All)	All	0	16	18				0	108	
I 469	Both (All)	All	0	18	20				0	108	
I 469	Both (All)	All	0	20	22				0	108	
I 469	Both (All)	All	0	22	24				0	108	
I 469	Both (All)	All	0	24	26				0	108	
I 469	Both (All)	All	0	26	28				0	108	
I 469	Both (All)	All	0	28	30				0	108	
I 469	Both (All)	All	0	30	30.831				0	108	

Rows 24-32 of 32 total rows

Peak Search Sub-segments (show_ins_fixed_analysis_single)

End MP	Target Crash Count	Coefficient of Variance	No. of Fatal Crash	No of Type A Inj Crash	No of Type B Inj Crash	No of Type C Inj Crash	FA C
4.35	6	0.403465	0	0	0	0	0
7	5	0.484158	0	0	0	0	0
4.25	4	0.605197	0	0	0	0	0
4.45	4	0.605197	0	0	0	0	0
4.55	4	0.605197	0	0	0	0	0
9	4	0.605197	0	0	0	3	0
4.95	3	0.806929	0	0	0	0	0
5	3	0.806929	0	0	0	0	0
6.85	3	0.806929	0	0	0	1	0
8	3	0.806929	0	0	0	1	0
8.85	3	0.806929	0	0	0	2	0

Google Map (floating_gmap)

U.S. 24, Indiana
Address is approximate

U.S. 24

U.S. 24

Google

© 2012 Google - Terms of Use

QUESTIONS?

